



# Muller Pump Service Instruction

**Note: To replace two pumps in SP9 or Jet Twin two kits are required**

1501562K - Muller Pump Spares kit A (MIX, Jet & SP9)		
1501562	Pump Muller 24V Mini	1
1501563	Flow Reducer 9mm OD 4mm ID	1
1500582	Splice Connector Insulated 26 - 19 AWG	2
8800456	Double Sided Adhesive Square, 25mm x 25.4mm	1

## Procedure

1. Turn off the machine.
2. Disconnect the electrical supply from the mains.
3. Drain the machine fully.
4. Remove service panels.
5. Disconnect electrical supply to pump.
6. Remove old pump.

**NOTE step 7 is for SP9, Jet and Jet Twin only.**

7. Insert flow reducer (1501563) into pump outlet tubing. Wet the reducer beforehand to lubricate and if required use the blunt end of a biro to push the reducer in far enough to leave room for the pump connection.

**SP9**

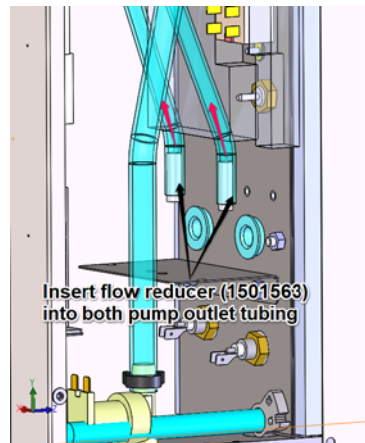

**Jet 6**

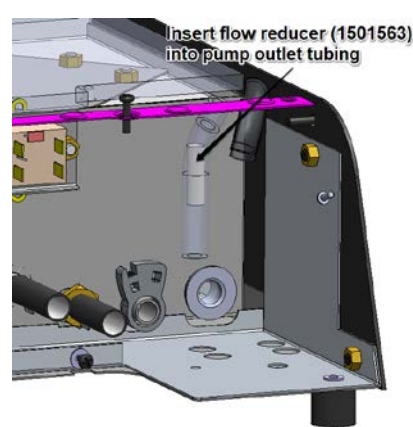

**Jet Twin**

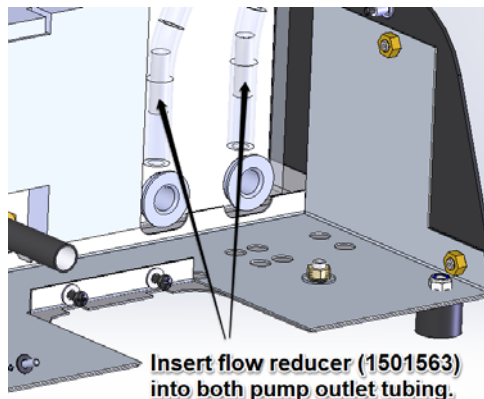

**Note: Step 8 is for Jet Twin Only.**

8. Wire new pumps together (red to red & black to black) using splice connector 1500582.

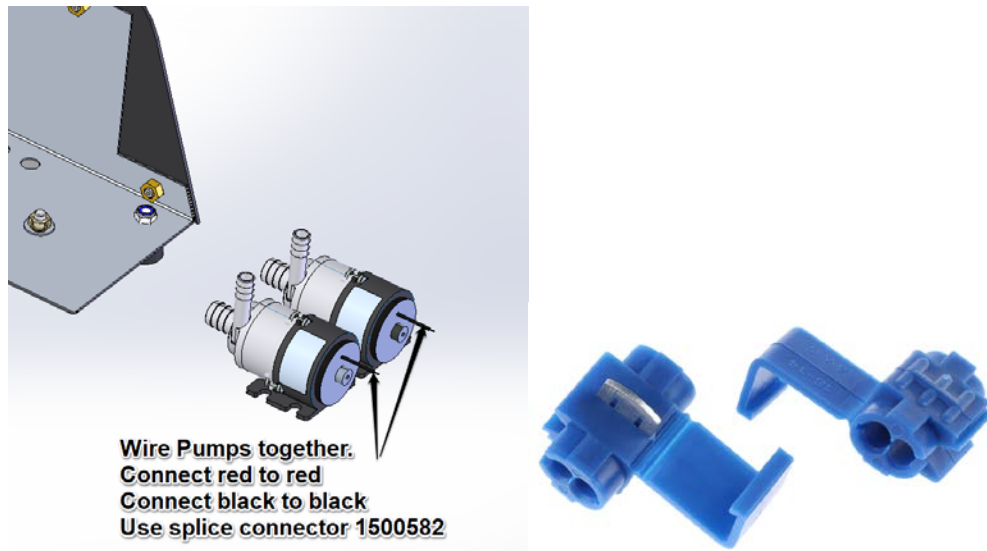

9. Place double sided adhesive square on the base of the pump to adhere to the chassis.
10. Insert pumps into tank location.
11. Rewire and re-plumb pumps.
12. Reassemble service panels.
13. Plug machine back into mains and turn on.
14. Wait for the machine to fully recover.
15. Recalibrate machine.