



TB10053

Topic:		TB No.: 10053- Distributor/Technician	Date: 07/04/2020
Affected Machines:	Ecoboiler, all variants/ Brewers all variants/ MIX all variants, Sp9 all variants	Priority: Low	Created By: Gareth Fitzpatrick
From Serial No.:	All	Created For:	Customers
From Date:	All	Pages: <u>2</u>	

Reinstating a Marco boiler/ brewer

Level of difficulty to modify: **Low**

Overview:

Due to the recent Global Pandemic, most Coffee brewers and water boilers have been switched off/ decommissioned. The time span will greatly vary depending on the Region effected so it is assumed many weeks of inactivity; which could result in Bacteria growth. Many of the brewers/ boilers have been fitted to an inline water filtration system. The filter will have stagnated water and debris which may contain harmful contaminants/ bacteria. It may be a good opportunity to review the filters age and replace, alternatively to reuse we suggest you contact the manufacturer of the filtration kit and follow the specific guidelines.

Reinstatement:

- Before Powering back on the machine for use we recommend emptying the tank contents (if not already done) and flushing two times, allowing the boiler to reach temperature for at least one of these flushes!
- In most instances this will be enough to get the machine up and running and fit for use. However; there will be instances where mineral deposits/ scale has settled on the inside of the tank and covered the probes meaning they will need to be cleaned/ descaled.
- For the Ecoboiler range, Two red flashing lights on the Ready status will indicate a scale/mineral deposit issue after approx. 10-15 mins after start-up. You can watch the video [here](#) to perform the descale operation.

Notes:

- **Always ensure the machine is isolated from mains Power before commencing any works!**
- All machines are fitted with drain hose's so you can conveniently drain the machine!
- Below are some useful images on how to access the drain hose in the main models.
- I include the website link address for the descale procedure for hard copy users. Just click on the videos section within the website page.



TB10053

- <https://marcobeveragesystems.com/products/ecoboiler-t10/>
- Please visit www.marcobeveragesystems.com to access Service manuals and other useful resources for each model variant.



Ecoboiler, single screw to remove front lower panel



Drain hose is located bottom left in all model variants.

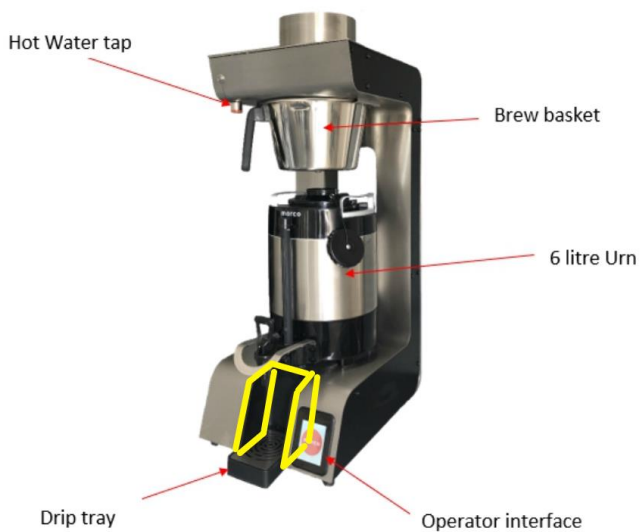

Drain hose is here!

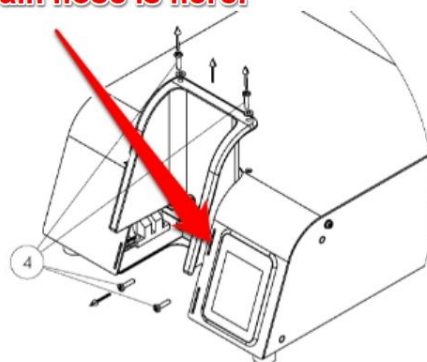

Note: Older model variants only have two securing screws!

Remove the yellow section to access the drain hose!