



FRIIA HC

A stylish, flexible undercounter hot/cold water system for hotels, cafes, or offices.

> 0.8 or 2.1 GAL boiler option



COMPLETE BUNDLE ORDER CODE

FRIIA HC 220v	5002864US
FRIIA HC 110v	1001864US
FRIIA HC Plus	5002866US

2B FONT 1000868



CHILLER 1001860US



MIX UC3 110v - 1001880 220v - 1000880US



OR

MIX UC8 1000887US



SYSTEM SET-UP

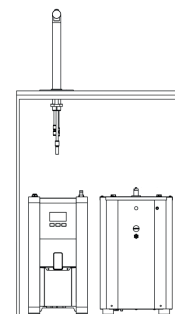

CHILLER SPECS

PRODUCT INFO	SIZE	PERFORMANCE SPECS			PLUMBING, ELECTRICAL AND TECHNICAL SPECS			
NAME ORDER CODE	DIMENSIONS (D X W X H inches)	GAL/HR	CUPS /HR	POWER @110v	PLUMBING REQS	COMPRESSOR POWER	CHARGE	REFRIGERANT
Chiller 1001860US	17.1 x 10.2 x 17.9	7.9-11.8 GALS/hr based on incoming water temp of 59°F and output water temp of 41-44°F	175-235 (ΔT = 18 °F)	180 W	3/8" Compression or 3/8" John Guest	1/8hp	45g	R290

A minimum operating pressure of >3 bar or 28 psi downstream of filter is required for optimum output l/min.

BOILER SPECS

PRODUCT INFO	SIZE	PERFORMANCE SPECS			PLUMBING & ELECTRICAL REQS		
NAME ORDER CODE	DIMENSIONS (D X W X H inches)	IMMEDIATE DRAW OFF	GAL/HR	CUPS/HR	POWER	NEMA	PLUMBING REQS
MIX UC3 - 110v 1001880	15.1 x 8.2 x 17.4	0.8 GAL	3.6 GAL	75	1.4kW @ 110v	5-15p	3/8" Compression or 3/8" John Guest
MIX UC3 - 220v 1000880US			7.3 GAL	156	2.8kW @ 220v	L6-20P	
MIX UC8 - 220v 1000887US	15.1 x 8.2 x 24.2	2.1 GAL					

FONT SPECS

NAME ORDER CODE	DIMENSIONS INC. DRIP TRAY (D X W X H in.)	DIMENSIONS EXCL. DRIP TRAY (D X W X H in.)	TAP TO COUNTER (in.)	DRAIN REQ'D
2b Font 1000868	6.6 x 4.7 x 11.2	5.4 x 1.1 x 11.2	9.7	Y

PACKAGING

NAME	PACKAGING DIMENSIONS (L X W X H inches)	WEIGHT
Font	11.4 x 22.4 x 8.4	4.4lbs
Chiller	19.2 x 11.8 x 20.2	69.4lbs
MIX UC3 - 220v/110v	17.7 x 11.4 x 21.2	25lbs
MIX UC8 - 220v	17.7 x 11.4 x 27.5	30.8lbs

PLEASE NOTE

FRIIA components (font, boiler and chiller) are packed and shipped in individual boxes.





FRIIA HOT/COLD/SPARKLING

COUNTER CUT-OUT WITH DRIP TRAY	FRIIA HC 220v 5002864US	FRIIA HCS 220v 5002865US	FRIIA HC PLUS 5002866US
	FRIIA HC 110v 1001864US	FRIIA HCS 110v 1001865US	FRIIA HCS PLUS 5002867US

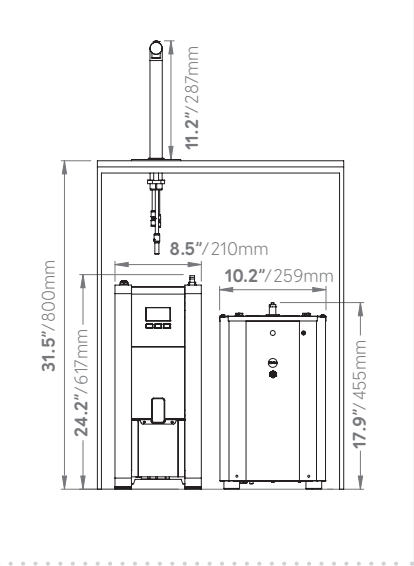
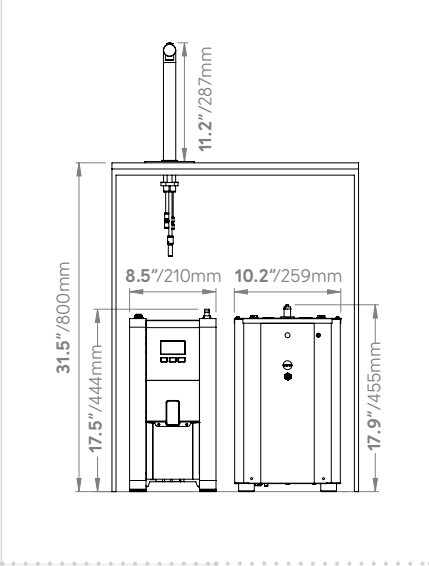
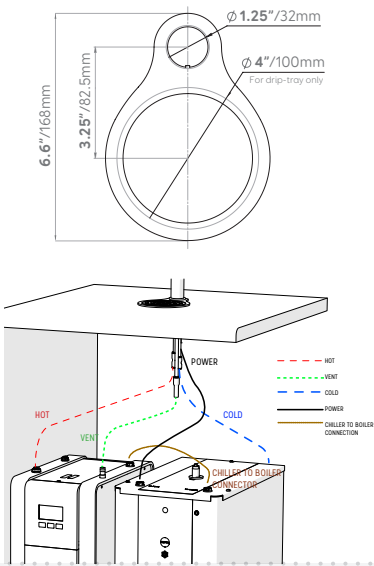

VENTILATION REQUIREMENTS

FRONT VENTILATION: Ventilation grilles cut out of standard cabinet door.

SIDE VENTILATION: Ventilation grilles cut out of standard 600mm cabinet. Grilles may be fitted on either side as long as they ventilate into an open unobstructed area.

BASE VENTILATION: Ventilation grilles cut in base panel and base plinth, a grille must also be cut out at the top of the cabinet.

- At least 2 x vents 260mm/10.2" w x 65mm/2.5 h
- The cabinet may be ventilated in many ways provided there are cut outs placed near the base and another near the top of the cabinet to take advantage of natural circulation.

UNPACKING INSTRUCTIONS

- The chiller must be handled only in a vertical position. Transporting the appliance in a horizontal position can cause severe damage to the refrigerator.
- Remove the exterior and interior packing. Packing materials (especially any plastic bags) should be stored out of the reach of children, as a potential source of danger. When disposing packaging parts, please follow current regulations on the matter, separating carton from plastic parts.
- Always check that the equipment that is delivered corresponds to the model indicated in the accompanying document.
- The equipment is shipped in a cardboard box. Once the packaging has been removed, check the equipment has not been damaged in transit; if damage is found, notify the carrier.

ELECTRICAL INSTALLATION PROCEDURE

When installing the machine, always observe the local regulations and standards. The appliance is supplied with a moulded power cord. A suitable mains power supply socket should be available within easy access of the appliance so that it can be disconnected easily after install.

The standard machines are supplied with a UK 3-pin plug. For EU models a 2-pin CEE-7 plug will be supplied. US models will be supplied with the suitable plug. A suitable mains power supply socket should be available within easy access of the appliance so that it can be disconnected easily after install. The wires from the front are terminated in a Mini Fit connector which will plug into a similar Mini Fit connector mounted on the top lid of the undercounter boiler.

PLUMBING INSTALLATION PROCEDURE

- Ensure that the equipment is installed according to local plumbing & water regulations.
- Fit a stop valve on a cold water line and attach a 3/4" BSP male fitting, (eg. 3/4" x 1/2" 311 or washing machine type stop valve). Suitable fittings are supplied with the kit to attach to 3/8" Compression or 3/8" John Guest.
- Connect water supply lines following the installation drawings, as per installation guide.
- In case filter systems are used verify that they satisfy the requirements of the legislation in force.
- If the filter is new, turn on water and flush at least 10 liters (2.5 gallon) through the filter before to connect it to the cooler; if the filter is a used one, connect water inlet to the chiller.
- To ensure that the maximum value of pressure of 3 Bar is not exceeded the chiller integrates a pressure reducer.
- Turn on the water to flush any impurities, dust etc from the inlet hose and water pipe. Allow several litres through. Especially for new installations.

OPERATING THE CHILLER/CARBONATOR FOR THE FIRST TIME

- Before connecting the appliance to the power source, let it stand upright for approximately 2 hours. This will reduce the possibility of a malfunction.
- Check that all installation procedures have been carried out.
- Ensure water inlet is open.
- Before supplying power to the unit check water and Carbon Dioxide lines do not leak.
- Plug the chiller into a suitable socket switch ON/OFF switch on the rear of the chiller to ON position. The "Power ON Status" light will light-up.
- When the unit is on, the carbonation pump starts to fill. The carbonation device stops when it reaches the maximum level.
- Once water and CO₂ are connected, open the vent on top of the Chiller by pulling the ring. This operation allows the escape of any air bubbles present inside, which would affect the carbonation adversely.
- On the pressure reducer knob, adjust CO₂ pressure to a value between 50 and 65 PSI (350 and 450 kPa) (3.5 - 4.5 bar). This value depends on the temperature of the water and on the ambient temperature. The temperatures correspond to the CO₂ pressure.
- To enable filling the lines, open the two lines in the following order: cold sparkling water and cold natural water, until the flows appear regular and without the presence of air, in each case deliver and discharge at least 5 litres of water from each line.
- At this point you can dispense water.



FRIIA SYSTEM OVERVIEW

COUNTER CUT-OUTS

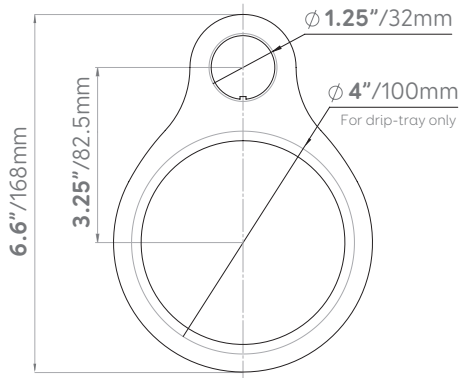

RADIUS OF MAXIMUM FONT PLACEMENT

Standard 31.5" high cabinet

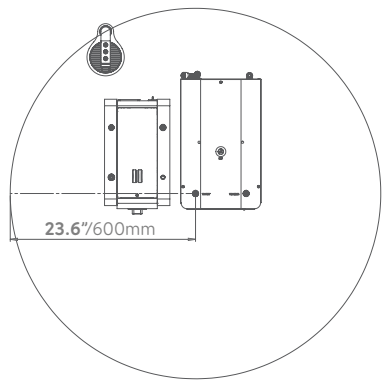

CABINET

Min: 31.5" (h) x 23.6" (w) x 23.6" (d) with 3.9" clearance around machines all sides

OPERATING ENVIRONMENT

Cannot exceed temperature of 95°F

VENTILATION

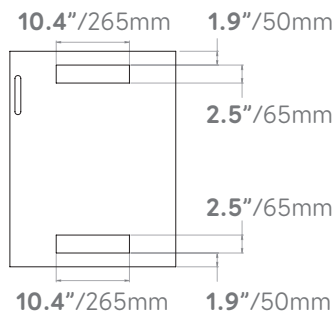
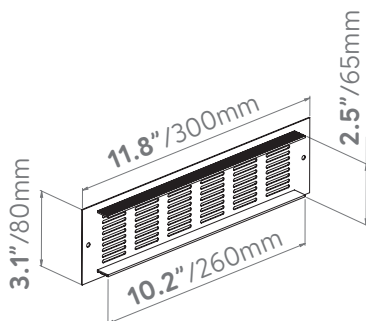
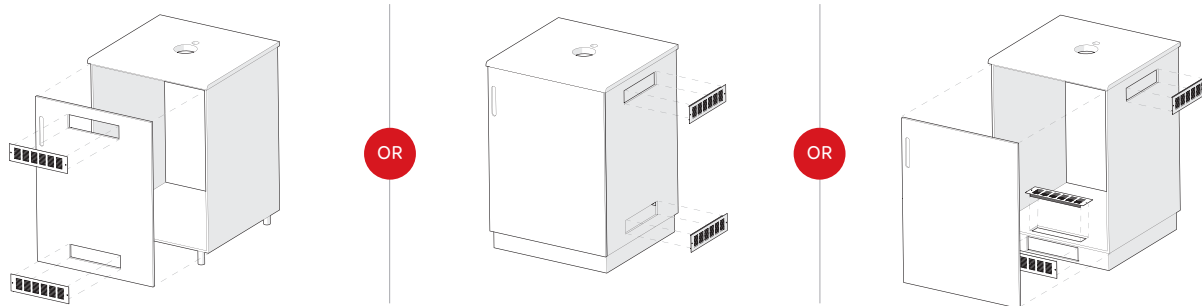

PLEASE NOTE

It is essential to allow for two ventilation points when installing FRIIA. Vents are not supplied. Where possible, we recommend removing the back of your cabinet.



FRIIA PERFORMANCE & MAINTENANCE

FRIIA OUTPUT VOLUME

Based on flow rate of 0.3 GAL/min and ambient temperature of 68-77°F. Chart indicates FRIIA chilling capacity based on incoming water temperature and desired output water temperature.

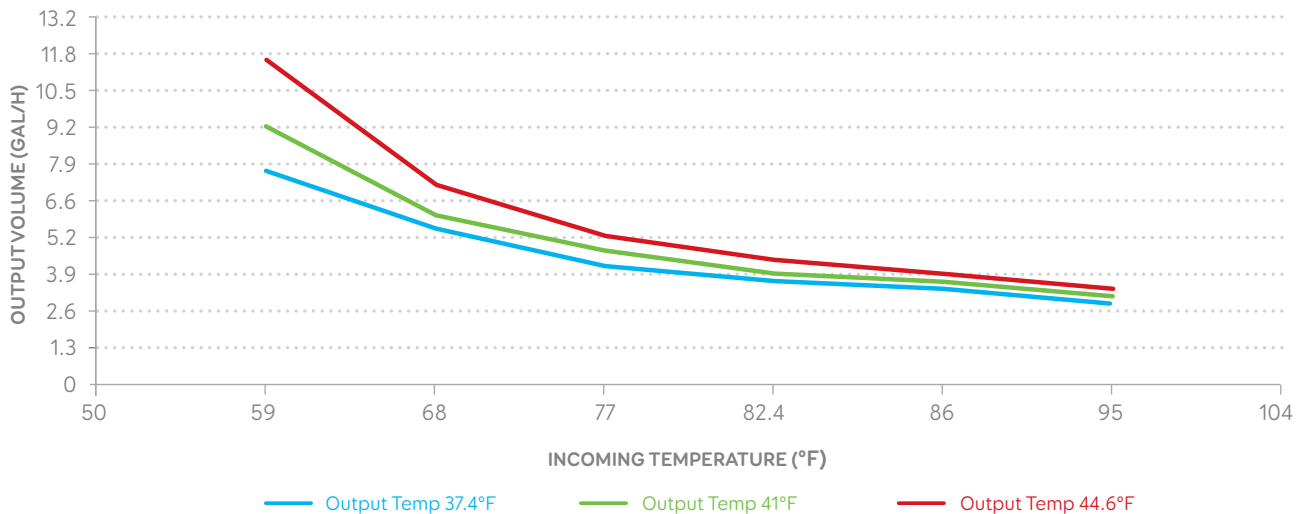

HOW TO CLEAN FRIIA

- > Wipe down front daily with non-abrasive cleaner.
- > Sanitize the chiller every 6 months, after a filter change or after a period of inactivity (more than 72 hours). Visit our YouTube channel for further instruction.

MAINTENANCE

- > FRIIA requires use of both a HOT (scale reducing filter if limescale is present) and COLD (carbon block for taste and odour) water filters for FRIIA. Please contact us for advice on the best water filter.
- > Descale the MIX boiler if scale is present in the water.