



POUR'D TOUCH

Beverage dispense
made easy

**COMPLETE BUNDLE
ORDER CODE**
POUR'D Touch
5001945US

> POUR'D TOUCH can be used to dispense beverages from any concentrate or syrup source.

FONT



CONTROL BOX



OPTIONAL

BOILER MIX UC3



- > To dilute with hot water
- > To add separate hot water

CHILLER / CARBONATOR FRIIA



- > To dilute with either chilled or sparkling water
- > To add separate chilled or sparkling water

RECOMMENDED DILUTION RATIOS

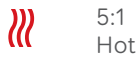

5:1
Hot



1:1 - 30:1
Cold/Sparkling

GOOD TO KNOW

**POUR'D TOUCH
can be used with:**
Concentrates & Syrups with
Max Viscosity of 700 CPS

Minimum 4ml concentrate
to 125ml final beverage

POUR'D TOUCH SET-UP

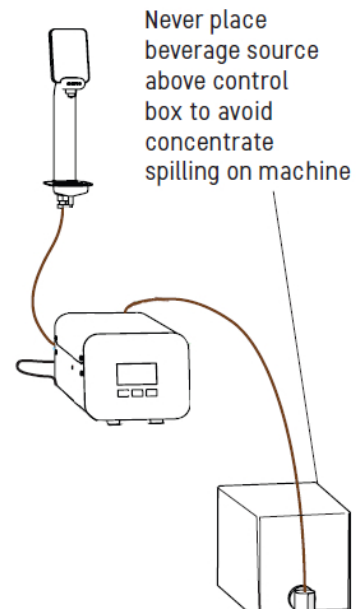



POUR'D SPECS

	OPTIONAL				
	FONT	CONTROL BOX	BOILER		CHILLER / CARBONATOR
	POUR'D TOUCH FONT 1000990	POUR'D Touch Control Box 1001945US	MIX UC3 220v - 1000880US	MIX UC3 110v - 1001880	FRIIA 1001860US / 1001861US
Dimensions (D x W x H inches)	7.70 x 4.68 x 17.36 (Incl. drip tray)	13.37 x 6.2 x 5.5 (width not including tubing)	15.1 x 8.2 x 17.4		17.1 x 10.2 x 17.9
Power	—	40W, 0.17A @ 110V	2.8kW @ 220v	1.4kW @ 110v	180W @110v
Plumbing	—	3/8" Compression or 3/8" push fit	3/8" Compression or 3/8" John Guest		3/8" Compression or 3/8" John Guest
NEMA	—	5-15p	L6-20P	5-15p	5-15p
GAL/HR	—	33.3	7.3	3.6	7.9-11.8 GALS/hr based on incoming water temp of 59°F and output water temp of 41-44°F
Performance Specs	—	Dilution Range: 1:1 - 30:1	Immediate Draw Off: 0.8 GAL		Cups/HR: 175-235 (ΔT = 18 °F)
Compressor Power	—	—	—	—	1/8hp
Charge	—	—	—	—	45g
Refrigerant	—	—	—	—	R290

PACKAGING

ITEM	PACKAGING DIMENSIONS (L x W x H inches)	WEIGHT	QTY / PALLET
Font	33 x 13 x 7.9	12.4lbs	24
Control Box	18.1 x 10.4 x 13	15.9lbs	36
MIX UC3 - 220v/110v	17.7 x 11.4 x 21.2	25lbs	24
FRIIA Chiller/Carbonator	19.2 x 11.8 x 20.2	69.4lbs	5

POUR'D CAN DILUTE/DISPENSE:

Non-Dairy Milks	✓	Dairy Milk	✗
Syrups	✓	Thick Syrup/Molasses (>700 CPS)	✗
Concentrates	✓	Kombucha	✗
Juice (no pulp, <700 CPS)	✓	Powder	✗
RTD Cold Drinks	✓	RTD Hot Drinks	✗

RECOMMENDED SET-UP & CLEARANCE REQUIREMENTS

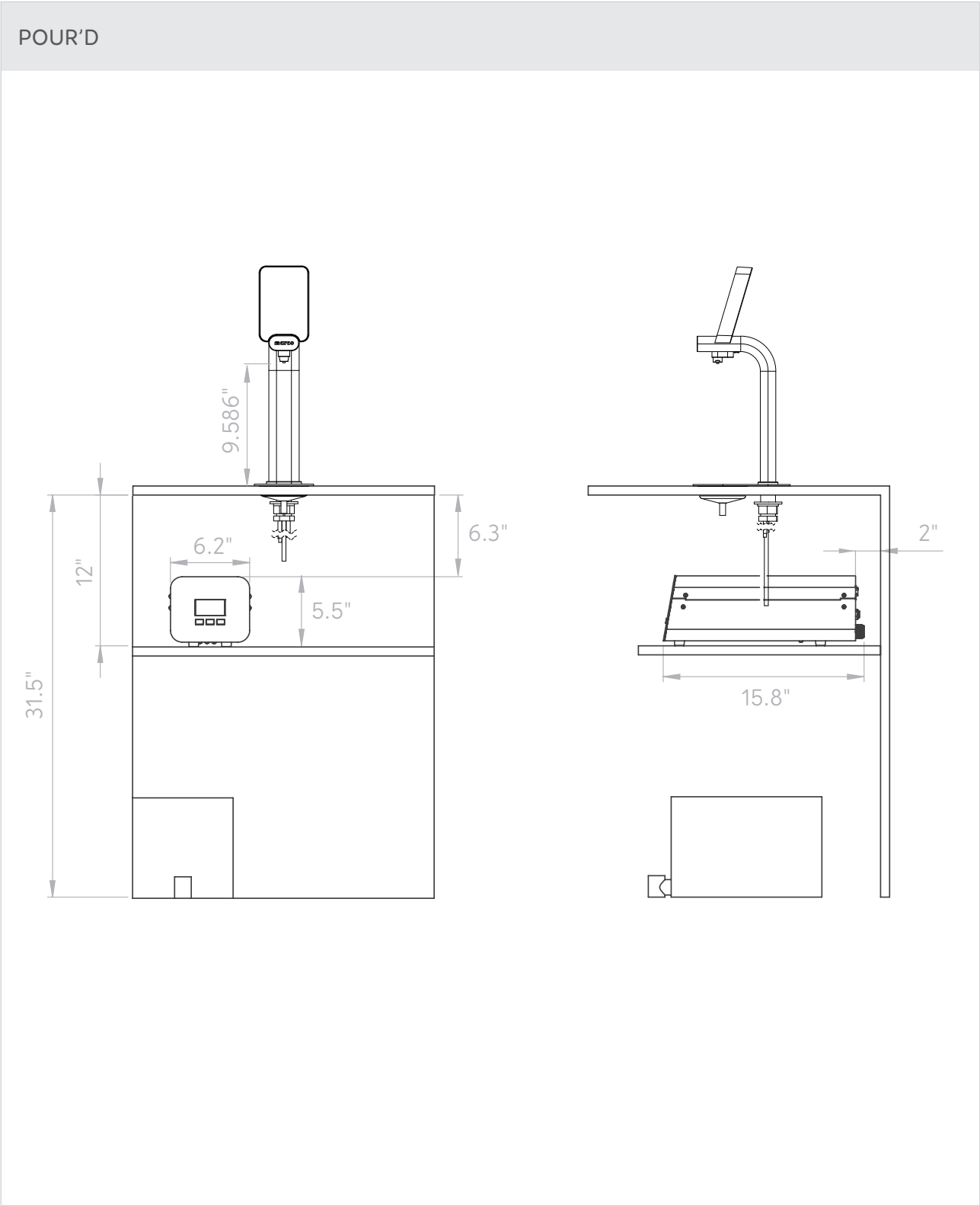

RECOMMENDED SET-UP & CLEARANCE REQUIREMENTS

POUR'D WITH MIX UC3

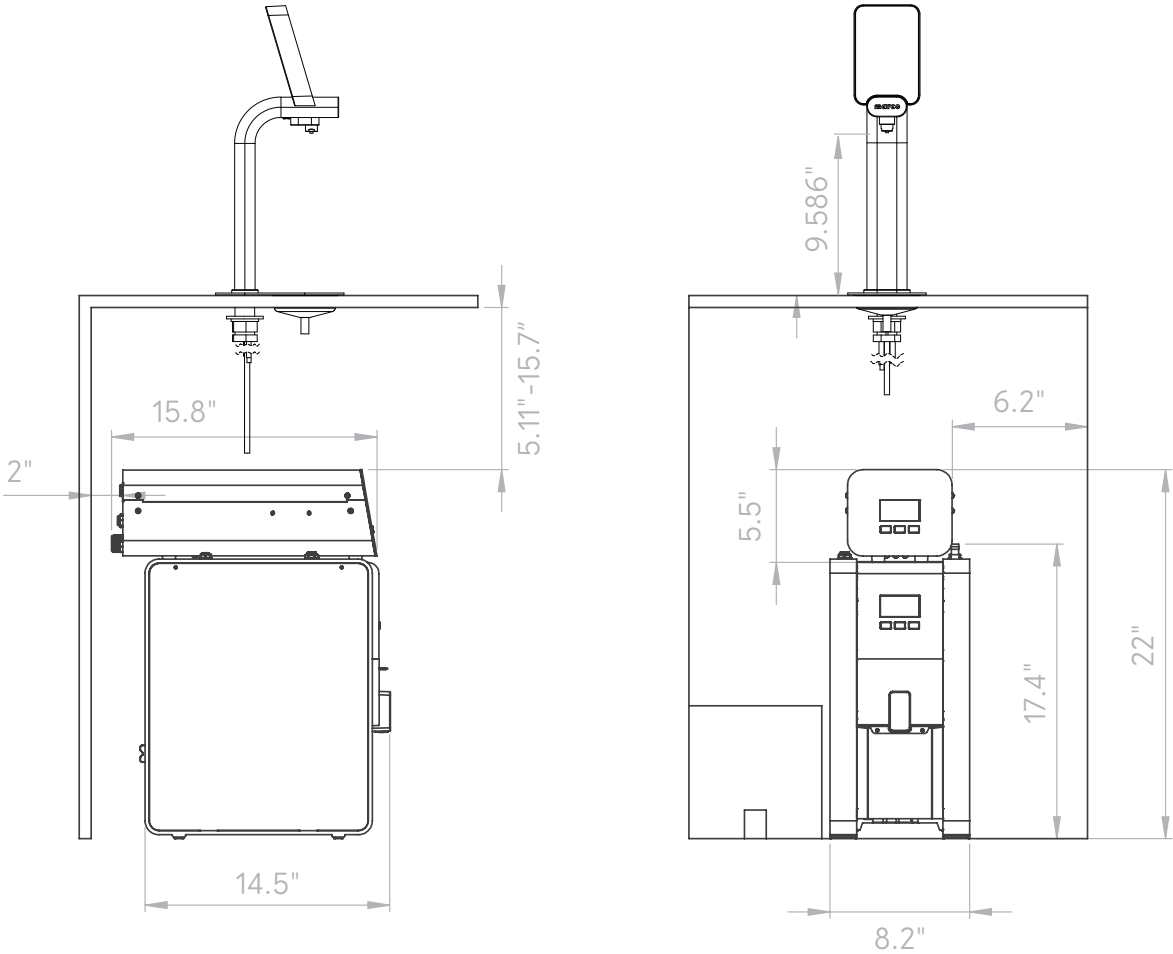

RECOMMENDED SET-UP & CLEARANCE REQUIREMENTS

POUR'D WITH FRIIA

